

# MARVEL SPIDEY AND HIS AMAZING FRIENDS

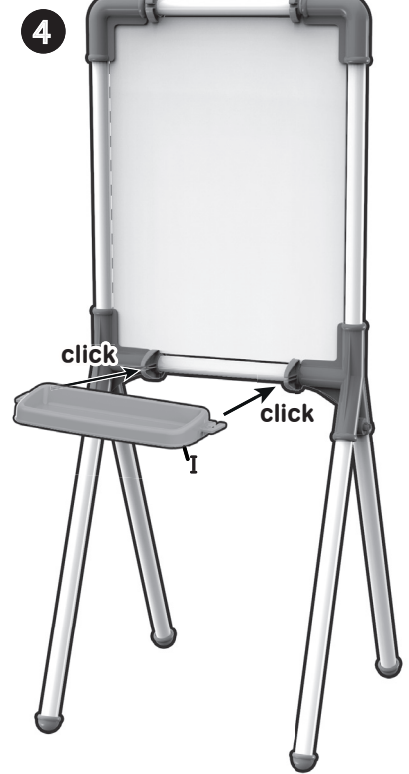
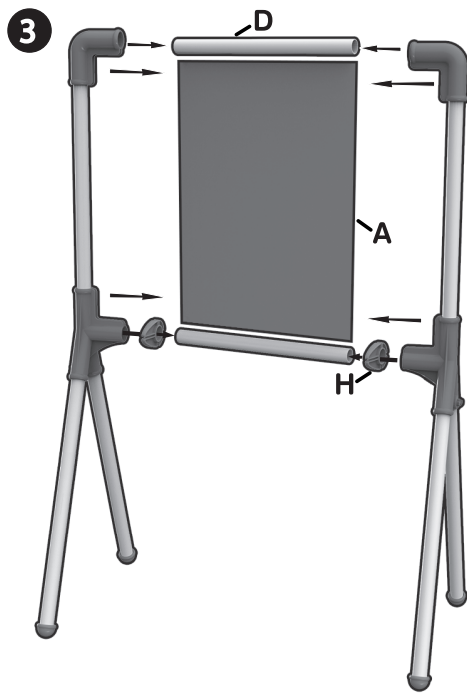
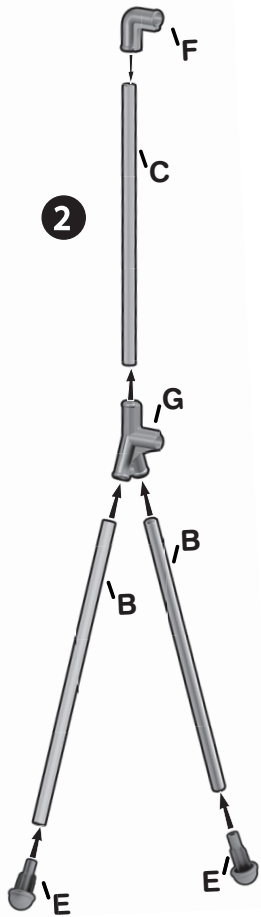
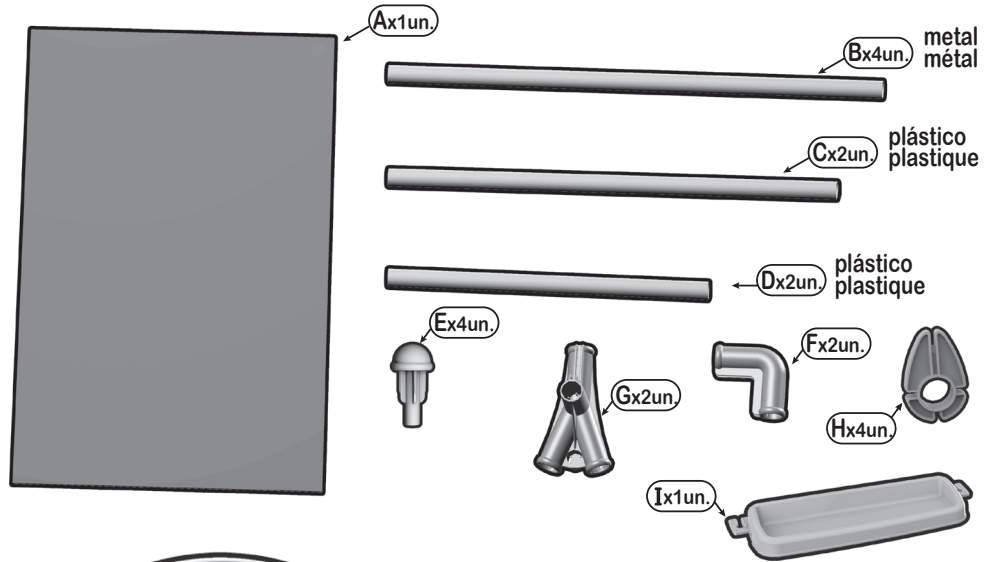

MARVEL © 2023 MARVEL

(\*)

**es** Para facilitar el montaje, recomendamos sumergir en agua caliente durante 5 minutos.  
**en** To make it easier to assemble, we recommend immersing it in hot water for 5 minutes.  
**fr** Pour faciliter le montage, nous recommandons de le plonger dans l'eau chaude pendant 5 minutes.  
**pt** Para facilitar a montagem, recomendamos submergir em água quente durante 5 minutos.  
**de** Zur Erleichterung der Montage, raten wir, es 5 Minuten lang in warmes Wasser zu tauchen.  
**it** Per facilitarne il montaggio raccomandiamo di immergere in acqua calda per 5 minuti.  
**pt** Para facilitar a montagem, recomendamos submergir em água quente durante 5 minutos.  
**nl** Om de montage te vereenvoudigen, raden we aan om de motor gedurende 5 minuten in warm water te dompelen.  
**ru** Для облегчения сборки рекомендуется погрузить в горячую воду на 5 минут.  
**no** For å gjøre monteringen enklere anbefaler vi å legge leken i varmt vann i 5 minutter.

**sv** För att underlätta monteringen så rekommenderar vi att den sänks ned i varmt vatten under 5 minuter.  
**fi** Kokoamisen helpottamiseksi suosittellemme upottamaan lelun kuumaan veteen 5 minuutiksi.  
**da** For at gøre det nemmere at stige op på den anbefaler vi at putte den ned i varmt vand i 5 minutter.  
**pl** Dla ułatwienia montażu zalecamy zanurzyć na 5 minut w gorącej wodzie.  
**cs** Pro snazší sestavení doporučujeme na 5 minut ponořit do teplé vody.  
**sr** Radi lakšeg sklopanja, preporučujemo uranjanje u toplu vodu na 5 minuta.  
**hu** A könnyebb összeszerelés érdekében ajánlott 5 percet meleg vízbe mártani.  
**sk** Pre uľahčenie montáže, odporúčame ponoriť na 5 minút do teplej vody.  
**el** Για πιο εύκολη συναρμολόγηση, συνιστούμε την εμβύθιση σε ζεστό νερό για 5 λεπτά.  
**tr** Daha rahat kurulum yapmak için, parçaları 5 dakika sıcak suda bekletmenizi öneriyoruz.  
**pt** Para facilitar a montagem, recomendamos submergir em água quente durante 5 minutos.

**ar** نوصي بغمرها في الماء الساخن لمدة 5 دقائق لتسهيل تجميعها.

